

Actualism, Ontological Commitment, and Possible World Semantics

Christopher Menzel

Here are some quotes representative of a widely shared belief.

[Possible world semantics] carries a commitment to the reality of possible worlds and possible individuals.¹

[Kripke-style semantics] includes a function which maps each member of a set of possible worlds to the set of objects existing in that world, objects which need not exist in our world. Thus, truth-conditions are given in terms of a totality of all possible objects, including nonactual possibles.²

A semantical theory is committed to the reality of the entities it uses in its explanations. . . . The Montague grammarian, or other possible worlds theorist, is committed to possible worlds and needs to tell us what they are if we are to take their theory seriously. Saying they are “just indices” is not a responsible theory.³

I am an actualist. I think that whatever exists—whatever has *being* in any sense—is actual. Thus, I don’t think there are any merely possible objects or any merely possible worlds. Furthermore, I am skeptical of proposed actualist reconstructions of these notions. Nonetheless, I like possible world semantics. A lot. I think it reflects—in a certain sense—the modal structure of reality, that it yields correct truth conditions for much of our modal discourse, and indeed, in the guise of Montague Grammar, that it provides

¹H. Hodes, “Individual Actualism and Three-valued Modal Logics, Part I: Model-theoretic Semantics,” *Journal of Philosophical Logic* 15 (1986), p. 369.

²A. McMichael, “A New Actualist Modal Semantics,” *Journal of Philosophical Logic* 12 (1983), p. 97 (henceforth NAMS).

³J. Barwise and J. Perry, “Shifting Situations and Shaken Attitudes,” *Linguistics and Philosophy* 8 (1985), p. 116.

a powerful basis for a full blown semantics for much of natural language. Contrary to the belief represented in the quotes above, I think it does all this without any commitment to possible worlds, mere possibilia, or their actualist counterparts. Here I will say why.

1 Plain Vanilla Semantics

My starting point is plain vanilla, nonmodal semantics for first-order languages. The usual story, in which we can acquiesce for the time being, goes something like this. A language is an uninterpreted formal system whose elements are the result of recursively applying certain rules of construction to an initial set of basic elements. Thus, more exactly, we can think of a first-order language \mathcal{L} as a pair $\langle Lex, G \rangle$ whose first element is a (first-order) *lexicon*—terms (variables and constants), n -place predicates, logical constants, and the like—and whose second element is a *grammar* that generates all the well-formed formulas of the language from the lexicon in the standard fashion.

Hand in glove with the notion of such a language goes the idea of a first-order *model*, relative to which such semantical notions as truth and (more ambitiously) meaning, can be defined. Such a model can be defined as a pair $\langle D, R \rangle$, where D is an arbitrary set of objects, and $R = \{R_n : n \in \mathbb{N}, n > 0\}$, where each R_n is the set of all subsets of D^n .⁴ The members of D are often called the “individuals” of the model, and each set R_n is thought of as the set of (extensional) n -place relations among the individuals in D .

The connection between a language and a model is provided by means of a *valuation* function. Thus, given a language \mathcal{L} and a model $\mathbf{M} = \langle D, R \rangle$, a valuation function V assigns elements of D to the terms of \mathcal{L} , and elements of R_n to the n -place predicates. The pair $\langle \mathbf{M}, V \rangle$ is called an *interpretation* I of the language. So armed we can define for formulas of \mathcal{L} the notion of truth in, or relative to, the model \mathbf{M} under I in the usual way in terms of an extension V' of V that maps formulas into a set of “truth values” (e.g., the set $\{0,1\}$).⁵

Now, among other things perhaps, a semantic theory is supposed to tell us something about truth. Indeed, our plain vanilla semantics above, or something like it, is often (though somewhat inaccurately) referred to as

⁴I.e., the n^{th} Cartesian product of D with itself.

⁵Since I've stipulated I to be defined on terms generally, there is no need to bring variable assignments into the picture. This simplifies matters for our purposes here.

“Tarski’s theory of truth”. But so far all we have is the notion of truth-in-a-model, or more exactly, truth-of-formulas-in-an-uninterpreted-language-in-a-model-under-an-interpretation. How does truth plain and simple fit into the picture?⁶

Something along these lines, I think. Truth and falsity attach (perhaps indirectly) to declarative sentences that we use in natural language. Which of these attaches to a sentence (on a given occasion of use) is a function of two parameters: its linguistic meaning, and the world.⁷ Otherwise put, given that a sentence means what it does, the world then determines whether or not it is true. Thus, ‘Russell wrote *The Principles of Mathematics*’ is true both in virtue of the fact that it means what it does (and not, say, what ‘Stalin signed *The Declaration of Independence*’ means) and in virtue of how the world is. If either had been different—its meaning or the world—it might well not have been true. If a semantic theory is going to provide a genuine theory of *truth*, then, first, there must be some way of applying it to (at least a fragment of) natural language; and second, we must be able to consider the theory, as far as it goes anyway, to be a reliable guide to the structure of the world. For only thus can it be taken to characterize correctly (modulo some degree of detail or “granularity”) the world’s contribution to the determination of a sentence’s truth value.

Since not every natural language (specifically, English) construction has a first-order counterpart, applying our first-order semantics to natural language is a matter of isolating an appropriate natural language fragment, i.e., some set of natural language sentences whose “logical form” is plausibly represented by well-formed formulas of the sort generated by our grammar. Here’s one way. Begin by keying on some collection of English names and verb phrases (perhaps conveniently abbreviated) to serve as the constants and predicates of a lexicon Lex . A corresponding grammar G will then generate a set $G(Lex)$ of well-formed formulas from this lexicon in the usual way. $\mathcal{L} = \langle Lex, G \rangle$ is thus a language in our formally defined sense. Let $NL(Lex)$ be those sentences of natural language whose logical form is represented by some formula in $G(Lex)$. $NL(Lex)$ is then a fragment of natural language to which our theory can apply in virtue of its formal “interpreted” counterpart \mathcal{L} . (For simplicity, I’ll assume that for each sentence S in $NL(Lex)$ there is exactly one formula $LF(S)$ in $G(Lex)$ that represents its logical form.)

⁶Compare Hodes, op. cit., p. 369.

⁷See A. Gupta, “Modal Logic and Truth,” *Journal of Philosophical Logic* 7 (1978), pp. 441-472, esp. Section III; also J. Etchemendy, *The Concept of Logical Consequence*, ch. 2, forthcoming from Harvard University Press.

How then does our semantics function as a reliable picture of reality? How is the world’s contribution to the truth value of the sentences of our fragment of natural language characterized? Directly. When it is truth plain and simple we’re after, our notion of truth-in-a-model will still do the job for us, albeit only when we turn our gaze to models of a very special sort: those which the world itself provides. More exactly, for any given chunk of ordinary language like $NL(Lex)$ there is typically some piece of the world that it is *about*, some set of objects—planets, U.S. congressional representatives, natural numbers, items in the fridge—to which the terms of the chunk refer, and over which its quantifiers range. This set can then form the basis of a model $\langle D, R \rangle$ —the *intended model*—of its interpreted counterpart \mathcal{L} whose domain D consists of the very things being talked about and quantified over and whose second element R contains, for each $n > 0$, the set of all extensional n -place relations over D . We can then define the *intended interpretation* $I = \langle \mathbf{M}, V \rangle$ for \mathcal{L} in its intended model $\langle D, R \rangle$ to be the result of defining our valuation function V such that the semantic values of our chosen names are their *actual denotations*, and the values of our chosen predicates are their *actual extensions*.⁸ Truth plain and simple is now straightforward: a sentence S of $NL(Lex)$ is true just in case its formal counterpart $LF(S)$ is true in \mathbf{M} under I .

2 Possible World Semantics

Truth for nonmodal languages is essentially a matter of how things are in the actual world. We captured this in our formal semantics, relative to a given language, by means of a particular model that *represents* the world as it is (albeit in a rather coarse fashion). *Necessary* truth, though, is not just a matter of how the world actually is, but of all the other ways it might have been as well, all other *possible* worlds. Thus, we can get a semantical grip on necessary truth by considering, not just a single model, but an entire *cluster* of models, each representing one of the many possible ways the world might have been, one of the many other possible worlds.

This is the sort of pep talk that often accompanies the presentation of a system of possible world semantics. At this stage of the game things are

⁸See, e.g., J. Hintikka, “Semantics for Propositional Attitudes,” in L. Linsky, *Reference and Modality* (Oxford: Oxford University Press, 1971), pp. 147-8; W. Hanson and J. Hawthorne, “Validity in Intensional Languages: A New Approach,” *Notre Dame Journal of Formal Logic* 26 (1985), p. 10.

quite indefinite. The major concern is with getting a fix on the right sort of semantical apparatus for necessity. There is talk of the world, of ways it could be, of other possible worlds and perhaps the things that exist in them, and it is suggested that these are the key to an adequate modal semantics. To this extent there is acknowledgement of metaphysical commitments of *some* sort which will have to be faced if the semantics is to provide a genuine theory of truth. But what those commitments are—exactly—and what the relationship is between them and the corresponding model theory, is not at this point the main focus.⁹ This is entirely appropriate. There is a certain amount of bootstrapping involved in the development of a logic *cum* semantics *cum* metaphysics of modality. We begin with our modal intuitions as manifested in our modal discourse. These corroborate, and are corroborated by, the imagery of possible worlds, which in turn pumps (some might say “perverts”!) the intuitions further. Intuitions and imagery together drive the construction of a formal logical and semantical apparatus. Once the apparatus is in place, at least tentatively, it can (and will, below) serve as the focal point of the surrounding metaphysical issues. Until then, rigorous discussion of those issues can (and will, for now) be held in abeyance.

The idea, then, is to get at necessity via clusters of models. It’s a good one. Or at least it’s a good start. But it has a couple of deficiencies as things stand. Our modal semantics has (at least) two jobs to do. On the one hand, as we have inspecifically acknowledged, we want it to reflect the structure of modal reality, whatever this comes to. On the other hand, we want it adequately to characterize the relation between language and that reality. Clusters of plain vanilla models as they stand, however, are in need of supplementation on both counts.

Regarding the first, a cluster of such models would provide a dim vision of modal reality indeed. To see this, note that things could have been different in one of two ways: there could have been more or fewer individuals, or the individuals there are could have had different properties and stood in different relations to one another. Distinct plain vanilla models can capture the first sort of difference all right (simply in virtue of having different domains), but not the second, since for any given set S we get only one plain vanilla model: the model $\langle S, R(S) \rangle$, where $R(S)$ is the set (appropriately

⁹Thus Kripke: “The basis of the informal analysis which motivated these definitions is that a proposition is necessary if and only if it is true in all ‘possible worlds.’ (It is not necessary for our present purposes to analyze the concept of a ‘possible world’ any further.)” S. Kripke, “A Completeness Theorem in Modal Logic,” *Journal of Symbolic Logic* 24 (1959), pp. 1-15.

partitioned) of all extensional n -place relations on S . Finer discriminations can be made only relative to some background language whose predicates could then be interpreted in different ways in the same model.¹⁰ However, since the models intuitively represent different ways the world could have gone, we should prefer them in and of themselves to reflect and explain the differences in interpretation, rather than having to appeal to differences in interpretation in order adequately to represent different ways the world could have gone. Hence, a language-independent solution to this shortcoming is much to be preferred.

Regarding the second, we noted above that there are two central parameters that determine a sentence's truth value: what the sentence means, and what the world is like. In modal semantics, we hold meaning fixed; we are interested only in changes on the world's side of things: we want to depict, given the meaning of a sentence, how its truth value varies with changes in the world; or more accurately, what its truth value would have been had the world been different in certain respects. However, if we use clusters of plain vanilla models in our modal semantics, the fixity of meaning will be lost, or at best, hidden. To see this, suppose we have a given cluster of models, each model representing a different way things could have been. Consider two models \mathbf{M} and \mathbf{M}' in the cluster and suppose a predicate P is assigned extension E relative to \mathbf{M} and extension E' ($\neq E$) relative to \mathbf{M}' . Intuitively, these changes in P 's extension relative to the two models are supposed to reflect different ways the world could have been, different ways in which P 'ishness could have been exhibited. But how is this nailed down in the semantics? How is this to be distinguished from a case of mere ambiguity, mere change in the linguistic meaning of P ? Granted, that is not our *intention*. But there is nothing answering to this intention in the semantics itself. There is, in short, nothing in the semantics that captures the fixity of meaning, nothing stable across models that pins down the meaning of the predicate.

The diagnosis here is not difficult. In regard to the first point, plain vanilla models fail in their characterization of modal reality, of course, because their properties and relations (i.e., the semantic values of predicates) are extensional; they cannot, e.g., represent the *same* property having *different* extensions in different situations since extensions just *are* properties on

¹⁰As happens in Kripke semantics. His quantificational model structures are essentially clusters of plain vanilla models indexed in a way that permits "indiscernible" models, i.e., models with the same domain. Such models can be distinguished "qualitatively" only relative to a language and corresponding valuation function.

this approach. By the same token, the reason a cluster of plain vanilla models can't distinguish a change in the world from a mere change in meaning is that difference in extension (in general) accompanies both sorts of change. However, if we add a common set of properties and relations *in intension* to our models (or more accurately, make room for entities that play such a role in our definition of a model), then both shortcomings are removed. Models with the same domain can be distinguished by assigning properties and relations different extensions in the models, thus capturing the second of the two ways mentioned above in which things could have been different. Furthermore, regarding the second point, by taking properties and relations (not implausibly) to be the meanings of predicates, we can fix their meanings across models despite assigning them different extensions.

Let's make all this prim and proper. First let's augment our definition of a plain vanilla model to make room for properties and relations in intension. It's a simple matter: we just replace the set R with a set $P = \{P_n : n \in \mathbb{N}, n > 0\}$ of pairwise disjoint sets, and add an "extension" function Ext that assigns a subset of D^n to each element of P_n . (So an augmented plain vanilla (*apv*-) model is a triple $\langle D, P, Ext \rangle$). A valuation function V for a language \mathcal{L} would then assign an element of D to each term of \mathcal{L} , and an element of P_n to every n -place predicate. In an arbitrary model, each P_n can be any set you please. But in the *intended* model for a given language (on this augmented conception of a model), P_n will be a set of bona fide n -place relations—the very ones, at least, expressed by the predicates of the language—and Ext will assign the right extensions in D^n to each such relation. Truth in a model will work in the obvious way, e.g., a formula of the form Pa will be true just in case $V(\mathbf{a}) \in Ext(V(\mathbf{P}))$.

Now we can turn to full-blown modal semantics. On the syntactic side, our notion of a language (for purposes here) just needs a small modal upgrade: the addition of an operator \Box to our logical apparatus and the appropriate formation rule to our grammar. On the semantic side, we define a *possible worlds* model to be a 6-tuple $\langle W, @, D, P, Dom, Ext \rangle$, where W is a set of indices, $@ \in W$, D is an arbitrary set, P is as above, Dom assigns subsets of D to elements of W , and Ext takes pairs $\langle w, p_n \rangle$ from $W \times P_n$ (for all $n > 0$) to subsets of $Dom(w)^n$.¹¹ For each index w , $\langle Dom(w), P, Ext_w \rangle$

¹¹Most modal semantics, including Kripke's own, stipulate only that Ext map such pairs to subsets of D^n . But, intuitively, this is to allow that something could have had a property without existing, contrary to the actualism that undergirds the view I will be developing. Note also that for convenience I'm not including an accessibility relation on W in this definition, so these structures will be **S5** models. This is not essential to my

is an augmented plain vanilla model (where Ext_w is the restriction of Ext to $w \times \bigcup P$). So in essence, with our emendations above, a possible worlds model can be thought of as a cluster of apv-models (indexed by W), as was the idea in the pep talk.

Given a possible worlds model \mathbf{M} and a modal language \mathcal{L} , an interpretation for \mathcal{L} will again be a pair $\langle \mathbf{M}, V \rangle$, where V is a valuation function which assigns elements of $Dom(@)$ to terms¹² and (as promised) elements of P_n to n -place predicates. (Note the assignment is made independent of any particular index; the “meaning” $V(P)$ of a predicate P is thus fixed across apv-models in the cluster—though of course its *extension* can (and typically will) vary.¹³) Given an interpretation $\langle \mathbf{M}, V \rangle$ for \mathcal{L} , truth for a formula of \mathcal{L} in \mathbf{M} relative to an index w will be defined in the obvious way, and truth in \mathbf{M} simpliciter will be defined as truth in \mathbf{M} relative to $@$. A formula $\Box\varphi$ in particular, of course, will be true in \mathbf{M} just in case φ is true relative to all indices w .

3 From Possible Worlds Semantics to Possibilia

As in our plain vanilla semantics, the question again presents itself: What of truth plain and simple? Formal theory up and running, we have exhausted our credit of imagery and indefiniteness. A correct theory of truth lays bear the connection between language and reality. Insofar as we want our formal semantics to provide such a theory, then, we have to tell an open and honest story about how it maps the structure of the world.

This is the point at which Kripke-style semantic theories (of which ours is in essential respects certainly a species) are taken to entail commitment to possible worlds and unactualized possible individuals. But what exactly is the argument here? The idea seems to be this. All the intended models for interpreted nonmodal languages can be thought of as submodels of a single all-encompassing model $\mathbf{M}' = \langle D', P', Ext' \rangle$, where the domain D' consists

arguments, though I think **S5** is *probably* the modal logic that best gets the modal facts right. For more on this, see my “The True Modal Logic,” under review.

¹²This restriction too is an actualism-inspired constraint, since it seems reasonable that we can’t name objects that don’t exist. It is dispensible, though (as is the restriction on Ext), for those with qualms.

¹³Compare R. Montague, “The Proper Treatment of Quantification in Ordinary English,” in R. Thomason (ed.), *Formal Philosophy: Selected Papers of Richard Montague* (New Haven: Yale University Press, 1974) pp. 247-270, esp. pp. 259-260, and E. Zalta, *Abstract Objects* (Dordrecht: D. Reidel, 1983), ch. 3.

of all the objects that actually exist,¹⁴ P' contains all n -place relations (appropriately partitioned), and Ext' assigns to each element of P' its actual extension. \mathbf{M}' thus represents, not just a piece of the actual world, but the actual world itself in its entirety. In virtue of this, truth for interpreted nonmodal languages generally can be defined simply as truth in M' , or more informally, truth in the actual world.

Now, taking our informal, intuitive talk of possible worlds and possible individuals *literally* as the “sober metaphysical truth” about modality, just as the actual world has its corresponding apv-model \mathbf{M}' , so every possible world w has its corresponding apv-model \mathbf{M}_w . The cluster of all such models forms the basis of a *distinguished* possible worlds model $\mathbf{M}^\diamond = \langle W^\diamond, @^\diamond, D^\diamond, P^\diamond, Dom^\diamond, Ext^\diamond \rangle$. Thus, in \mathbf{M}^\diamond , W^\diamond is—really and truly—the set of all possible worlds; $@^\diamond$ is the actual world; D^\diamond the set of all possible objects—actual and otherwise; $P^\diamond = P'$ is the set of all n -place relations; Dom^\diamond assigns to each world w the set of all objects in D that exist in w , i.e., those objects that would have been actual had been w ; and Ext^\diamond assigns, for each world w and n -place relation $p_n \in P_n^\diamond$, the correct extension of the latter in the former. Truth for interpreted modal languages generally can therefore be defined simply as truth in \mathbf{M}^\diamond .

Strictly speaking, of course, nothing follows concerning the contents of W^\diamond and D^\diamond ; for all that we’ve said in the previous paragraph, perhaps the only member of W^\diamond is $@^\diamond$, the actual world, and perhaps $D^\diamond = D'$, i.e., perhaps the only possible objects there are are the actual ones. What reason is there to think otherwise? The answer, of course, if \mathbf{M}^\diamond is to be considered a genuine representation of the modal facts, is that there must be at least as many possible worlds and possible individuals as are needed to yield an intuitively correct distribution of truth values among the modal sentences of (any interpreted fragment of) natural language. Consider, then, as noted, that one of the ways things could have been different is that

- (1) There could have been something distinct from every actually existing thing.

I, for example, might have had a third child. But clearly, for (1) to be true in our distinguished model \mathbf{M}^\diamond there must both be other possible worlds than

¹⁴To avoid problems with cardinality and nonwellfoundedness, mathematical objects (and perhaps even abstract objects generally) cannot be considered to be among all the objects there are. For those who insist on mathematical platonism, it is perhaps best to think of sets and numbers as objects of higher type, with which our first-order theory has nought to do.

$@^\diamond$, and other possible individuals than those that are actual; specifically, for the proponents of \mathbf{M}^\diamond , (1) is true iff there is a possible world in which some object exists that doesn't exist in the actual world, i.e., iff there is a $w \in W^\diamond$ and an $a \in D^\diamond$ such that $a \in \text{Dom}^\diamond(w)$ and $a \notin \text{Dom}^\diamond(@^\diamond)$. So if (1) and its ilk are to counted true, there must be other possible worlds and *merely* possible individuals.

In brief, then, here is the sort of argument we're after. The proponents of any semantic theory are committed to the existence of whatever entities are appealed to in its account of truth. Possible world semantics appeals to possible worlds and (merely) possible objects. It follows that the proponents of the former are committed to the existence of the latter.

4 Plantinga's Haecceitist Alternative

Thus the argument from possible world semantics to possibilia. Its strength, I think, is rather badly out of proportion with the ubiquity of its conclusion. There are two important assumptions in the argument that can be challenged: first, the tacit assumption that a theory of truth for modal languages requires a distinguished model; and second, that the distinguished model singled out must contain mere possibilia.

Let's take up the second assumption first. In many discussions of Kripke-style semantics, it is difficult to separate the intuitive trappings from the formal semantics proper.¹⁵ Hence, it is not hard to appreciate the naturalness of the distinguished model \mathbf{M}^\diamond (which we can call the *standard* model). But naturalness is one thing, inevitability quite another. The mandate is only that the proponents of a semantic theory tell *some* story or other about the connection between their formal semantics and reality. Hence, another model, with another underlying metaphysics, might do equally well. This was essentially Plantinga's insight.

The standard model poses a problem for actualists. Since for the actualist there are no mere possibilia, the set D^\diamond of all possible objects in the standard model is the very same set as the set of all actually existing objects, i.e., $D^\diamond = \text{Dom}^\diamond(@^\diamond)$. But as we saw, (1) is intuitively true. Its truth conditions in the standard model, however, require the existence of a $w \in W^\diamond$ and an $a \in D^\diamond$ such that $a \in \text{Dom}^\diamond(w)$ and $a \notin \text{Dom}^\diamond(@^\diamond)$. But since for the actualist, $D^\diamond = \text{Dom}^\diamond(@^\diamond)$, it follows that for all w , $\text{Dom}^\diamond(w) \subseteq \text{Dom}^\diamond(@^\diamond)$;

¹⁵See, e.g., G. Forbes, *The Metaphysics of Modality* (Oxford: Clarendon Press, 1985), pp. 28-38. Not that there is anything particularly wrong with this.

so, Plantinga wonders, “how can the actualist understand [(1)]”?¹⁶

Plantinga’s answer, as hinted at, was to supply a different distinguished model, one that both satisfies the actualist proscription on possibilia and yields the correct truth values for sentences like (1). Two conceptions of possible worlds dominate current lore.¹⁷ On one conception, worlds are understood to be alternate physical universes, concrete possibilia; on the other, worlds are identified with abstract objects of one sort or another. Plantinga opts for the latter view. Specifically, he identifies possible worlds with (in effect) *maximally* possible propositions, where a proposition p is maximally possible just in case it is possible and such that for any proposition q , p entails q or p entails *not- q* .¹⁸ The actual world $@^\dagger$ in particular is the maximally possible proposition that is true.

This doesn’t in and of itself separate Plantinga’s conception from the standard model (though the concrete conception of worlds is perhaps better suited to the standard model). The real difference is found in his notion of an *essence*, or *haecceity*. According to Plantinga, a property e is an essence just in case (i) it is possible for something to have e , (ii) necessarily, whatever has e has it essentially, and (iii) necessarily, if x has e , then it is not possible for anything but x to have it. Now, for Plantinga, essences, like all properties, exist necessarily. Furthermore, essences can exist unexemplified. These two features enable essences to play the role accorded to merely possible objects in the standard model. In place of the notion of a possible object existing in a world, Plantinga can speak instead of an essence being *exemplified* in a world, i.e., being such that the world (qua proposition) entails that the essence in question is exemplified; and in place of the notion of a possible object having a property r in a world, Plantinga can speak instead of an essence being *coexemplified* with r in a world, i.e., being such that the world entails that r and the essence in question are coexemplified.

In Plantinga’s intended model $\mathbf{M}^\dagger = \langle W^\dagger, @^\dagger, D^\dagger, P^\dagger, Dom^\dagger, Ext^\dagger \rangle$, then, the set D^\dagger is to contain, not the set of all possible objects—actual and otherwise—but rather the set of all essences—exemplified and otherwise. The

¹⁶A. Plantinga, “Actualism and Possible Worlds,” in M. Loux (ed.), *The Possible and the Actual* (Ithaca: Cornell University Press, 1979), p. 206 (henceforth APW).

¹⁷See P. van Inwagen, “Two Concepts of Possible Worlds,” *Midwest Studies in Philosophy, Volume XI: Studies in Essentialism* (Minneapolis: University of Minnesota Press, 1986), pp. 185-213.

¹⁸See his *The Nature of Necessity* (Oxford: Clarendon Press, 1974), ch. 4 (henceforth NN). Plantinga actually identifies worlds with maximally possible *states of affairs*, but the difference is unimportant for the matters at hand, since he takes there to be an isomorphism between propositions and states of affairs.

function Dom^\dagger then takes each world $w \in W^\dagger$ to the set of all essences that are exemplified in w ; and the function Ext^\dagger takes a given world w and n -place relation $p_n \in \bigcup P^\dagger$ (= the set of all relations) to the set of all n -tuples of essences that are coexemplified with p_n in w .

The truth conditions for (1) in Plantinga’s actualist model (call it the *haecceitist* model) are now straightforward: (1) is true just in case there is a world w and an essence e such that e is exemplified in w , and e is not exemplified in fact, i.e., just in case there is a $w \in W^\dagger$ and an $a \in D^\dagger$ such that $a \in Dom^\dagger(w)$ and $a \notin Dom^\dagger(@^\dagger)$. Formally, the truth conditions are identical with the truth conditions in the standard model. Unlike the standard model, though, because of the difference in its content, the haecceitist model entails no commitment to possibilia.

Plantinga’s haecceitist model shows that the argument for commitment to possibilia is unsound; the standard model is not the only route from our formal possible world semantics to a theory of truth. One might wonder though how much has been gained. While the abstract propositional conception of worlds is perhaps to be preferred to the concrete conception, it is not without its problems. It is threatened by paradox,¹⁹ its formal theoretical foundations are still rather seriously underdeveloped,²⁰ and the entire framework, for some tastes, is unduly baroque.

Furthermore, essences themselves—the heart of the haecceitist model—are not unproblematic. To see this, note first that some properties are most naturally picked out by means of expressions involving names, demonstratives, or other referential devices, and others are not. Thus, on the one

¹⁹See S. Bringsjord, “Are There Set Theoretic Possible Worlds?” *Analysis* 45 (1985), p. 64; C. Menzel, “On Set Theoretic Possible Worlds,” *Analysis* 46 (1986), pp. 68-72; P. Grim, “On Sets and Worlds: A Reply to Menzel,” *Analysis* 46 (1986), pp. 186-191. Grim’s paradox is akin to the paradox Russell reports in Appendix B of the *Principles*, which is also easily reconstructed in Plantinga’s framework as it stands.

²⁰It is not even clear that one can show there *are* any propositional possible worlds at all. Pollock offers a proof, but it is hard to find it convincing, since, first, it depends upon a rather elaborate theory of states of affairs whose consistency is not proved, and second, it makes two dubious assumptions: that every state of affairs has a complement, and that there is a set of all states of affairs that obtain; see his “Plantinga on Possible Worlds,” in J. Tomberlin and P. van Inwagen (eds.), *Alvin Plantinga* (Dordrecht: D. Reidel, 1985), pp. 121-144, esp. pp. 121-4. Plantinga offers a proof for a proposition that entails the existence of possible worlds in his reply to Pollock (pp. 328-9), but the proof is flawed; see C. Menzel, “On an Unsound Proof of the Existence of Possible Worlds,” forthcoming in the *Notre Dame Journal of Formal Logic*. An alternative world theory that doesn’t appear to suffer from these shortcomings is found in E. Zalta, *Intensional Logic and the Metaphysics of Intensionality* (Cambridge: MIT Press/Bradford Books, 1988), ch. 4.

hand, we have such properties as **living in Texas**, **being married to Xantippe**, **being as tall as that man**, and **being Reagan**, and on the other properties like **living somewhere or other**, **being married and happy**, and **being taller than every other man**. Call those of the latter sort *purely qualitative*.²¹ Intuitively, purely qualitative properties are, or are logical “compounds” of, *general* properties and relations, properties and relations that could be exemplified by more than one thing or, in the case of relations, more than one group of things,²² whereas properties that are not purely qualitative involve some nonqualitative component.

Now, if every object has a purely qualitative essence, then since purely qualitative properties presumably exist necessarily, there is reason to think that there are necessarily existing essences, as the haecceitist framework requires. But as Adams has argued,²³ convincingly I think, it does not seem possible that any collection of purely qualitative properties could be essential to some object without it being possible that they be exemplified by some other; at any rate, the assumption is reasonably doubted. This leaves two options for haecceitism: either essences are purely *nonqualitative*, or they have a purely nonqualitative component. Neither choice is especially happy.

The first option seems to me subject to a simple conceptual shortcoming. A traditional platonic understanding of properties—I would argue the dominant one—is that, at the most basic level, properties are what diverse but similar particulars have in *common*. That is, properties are, in the first instance, *general*; they are *universals*. But on this understanding there seems no justification for purely nonqualitative essences at all, since they are neither general themselves, nor logical compounds of general properties and relations. There is little enough to distinguish purely nonqualitative essences from concrete possibilia save a thin actualist veneer. In light of

²¹Compare Adams: “[A] property is purely qualitative...if and only if it could be expressed, in a language sufficiently rich, without the aid of such referential devices as proper names, proper adjectives and verbs (such as ‘Leibnizian’ and ‘pegasizes’), indexical expressions and referential uses of definite descriptions.” R. Adams, “Primitive Thisness and Primitive Identity,” *Journal of Philosophy* 76 (1979), p. 7.

²²Thus, even though the property **being taller than every other man** (i.e., $[\lambda x \text{MAN}(x) \wedge \forall y(\text{MAN}(y) \wedge x \neq y \rightarrow \text{TALLER}(x, y))]$) is not general, I take it to be purely qualitative, since it is a logical compound of the property being a man, the relation being taller than, and the identity relation, which are all general. For more on the idea of complex properties being logical compounds of other properties and relations, see, e.g., G. Bealer, *Quality and Concept* (Oxford: Clarendon Press, 1982).

²³Op. cit. and his “Actualism and Thisness,” *Synthese* 49 (1981), pp. 3-41. See also A. McMichael, “A Problem for Actualism about Possible Worlds,” *Philosophical Review* 92 (1983), pp. 49-66 (henceforth PAPW); see esp. pp. 57-61.

this understanding of properties, that too is stripped away, and haecceitism of this variety collapses into possibilism.²⁴ Perhaps there is another understanding of properties that is kinder to haecceities; but it is not at all obvious what that might be.

So maybe the second possibility fares better. Here an essence earns its abstract status by way of comprising one or more qualitative components. But what of the purely nonqualitative component? If this component is supposed to be a property, then the view runs afoul of the problems just noted. However, there is an alternative. Consider an essence like **being Reagan**, or **being identical with Reagan**. The name ‘Reagan’ is (on a widely held view) a *directly referential* term, a term whose semantic value (in a context) is exhausted by its referent. If we take the semantic value of a gerund to be a property, an appealing metaphysical corollary to this view of reference is that a gerund containing a name expresses a property in which the referent of the name (as opposed, say, to a sense) is itself a component. Thus, returning to the issue at hand, **being identical with Reagan** might be thought of as a complex comprising the relation of identity as its qualitative component, and *Reagan himself* as its nonqualitative component.

The trouble, though, is that if contingent objects like Reagan are actual *components* of essences, logical or otherwise, it would seem to follow that essences are *ontologically dependent* on those objects, i.e., that if an individual component of an essence had not existed, then the essence itself wouldn’t have existed either.²⁵ If so, the only way to salvage the view that all essences exist necessarily is to hold that their individual components exist necessarily. Assuming, as Plantinga does, that, necessarily, all individuals have an essence, it follows that essences exist necessarily only if all individuals do. But in that case, either (1) is false, or there exist things that are not actual, i.e., *possibilia*. Similarly, if an essence is ontologically dependent on the individual that exemplifies it, the claim that there are unexemplified essences makes sense only if we take an unexemplified essence to be an essence which, while exemplified (as it must be), is not exemplified by anything actual, i.e., an essence exemplified by a mere *possibile*.²⁶ But

²⁴Compare PAPW, pp. 60-1.

²⁵Compare Reagan’s singleton set {Reagan}. For more on the view that some intensional entities are ontologically dependent on contingent objects, see K. Fine and A. N. Prior, *Worlds, Times and Selves* (London: Duckworth, 1977), ch. 8; R. Adams, “Actualism and Thisness;” and A. Plantinga, “On Existentialism,” *Philosophical Studies* 44 (1983), pp. 1-20.

²⁶I omit consideration of essences like **being the person that would spring from**

mere possibilia are just what the view was designed to avoid. So although it is plausible enough that there are such properties as essences in this sense, it is by no means obvious that there are, or could have been, essences that exist either necessarily or unexemplified; not, at least, if we wish to shun possibilia. So even though Plantinga’s haecceitist model does indeed show that the standard model with its possibilist ontology is not inevitable, its own costs are too high for it to be a tenable alternative.

5 Modal Representation

What other options does the actualist have? Alan McMichael argues that, for the actualist, there are none within the confines of possible world semantics; a theory of truth for the semantics requires either possibilia or haecceities, so it must simply be rejected.²⁷ However, I find his own alternative semantics troublesome as well. McMichael suggests that we alter our understanding of what it is to say that an individual might have had a certain property. Thus, on his semantics, that Kripke might have been a carpenter is not ultimately a fact about *that* guy, *Kripke*, at least not directly. Rather it is a fact about the “maximal” purely qualitative property, or *role*, that Kripke alone in fact exemplifies, viz., that some role “accessible” to Kripke’s role includes the property of being a carpenter. This move abandons strong intuitions about *de re* modality and the semantics of names, and so, for my tastes anyway, is also unpalatable.²⁸

Despite McMichael’s pessimism, a further option remains for the actualist that we will explore in this section. This option challenges the first of the two assumptions in the argument from possible world semantics to possibilia, which I will call the *extensionalist fallacy*: that, as in the non-modal case, modal truth must be defined relative to a distinguished, intended model. This assumption seems to me to be the crux of the issue of ontological commitment in the semantics of modality. I will argue, by way of counterexample, that it is false.

I think that a lot of the unclarity surrounding modal semantics has arisen by not taking the idea that models are just that—models—seriously

A and B, where A and B are particular actually existing gametes that in fact never got together. If there are such essences (and this is not uncontroversial), then of course they are to be excepted from this claim. In any case, these alone are not sufficient to do the job Plantinga requires of essences generally.

²⁷PAPW, p. 62.

²⁸See NAMS, p. 75.

enough. That is, in general, semantic models are models in the ordinary sense: representations, or pictures, of a certain sort.²⁹ Consider a homey example. Suppose I wish to represent a few simple facts about my family, for example, that I have exactly two children, that my son Galen, and no one else, is (at the moment) not happy, and the like. I might draw a picture with four characters, stick figures say, and label them ‘Chris’, ‘Liisa’, ‘Annie’, and ‘Galen’, with the figures labeled ‘Chris’ and ‘Liisa’ somewhat larger than the other two. I could then label the entire picture ‘The Menzels’, and put a frowning face on the figure labeled ‘Galen’. On the other hand, I might take a more abstract approach and construct a model $\mathbf{M}_1 = \langle D_1, P_1, Ext_1 \rangle$, where D_1 consists of the numbers 1 to 4, P_1 the sets $\{10\}$ ($= (P_1)_1$) and $\{11\}$ ($= (P_1)_2$), and where $Ext_1(10) = \{1,2,3\}$ and $Ext_1(11) = \{\langle 1,3 \rangle, \langle 1,4 \rangle, \langle 2,3 \rangle, \langle 2,4 \rangle\}$. Corresponding to the labeling in the drawing I could define instead a representation function, or what I’ll call an *embedding* μ , for the model that maps the members of D_1 onto the members of my family, and the members of $\bigcup P_1$ onto the property \mathbf{H} of being happy and the relation \mathbf{P} of being a parent of, in the right sort of way.³⁰ We can picture \mathbf{M}_1 along with an appropriate embedding μ_1 as in Figure 1. In that figure, \mathbf{M}_1 and μ_1 together represent the familial situation in question no less, and indeed rather better, than the crude drawing.

The key to \mathbf{M}_1 ’s representational success is of course the existence of embeddings like μ_1 that are “faithful” to reality, to “the way things are”. To make this more precise, we define an embedding μ for an apv-model $\mathbf{M} = \langle D, P, Ext \rangle$ to be a total one-to-one function from elements of D to objects in the world, and from elements $p_n \in \bigcup P$ to n -place relations in intension. We say that μ is *faithful* just in case $\langle d_1, \dots, d_n \rangle \in Ext(p_n)$ iff $\mu(d_1), \dots, \mu(d_n)$ stand in the relation $\mu(p_n)$.

On this approach, the intended (apv-) model for an interpreted language is just one of infinitely many isomorphic models that serve equally well for defining truth. To drive the point home (and to lay some groundwork for further argument), for a given interpreted language \mathcal{L} and model $\mathbf{M} =$

²⁹See Etchemendy, op. cit., ch. 2, as well as his “Models, Semantics and Logical Truth,” *Linguistics and Philosophy* 11 (1988), pp. 91-106. Though Etchemendy doesn’t deal specifically with the semantics of modal languages, the account that follows was strongly influenced by several suggestive remarks in ch. 1 of his book.

³⁰Compare H. Kamp, “A Theory of Truth and Semantic Representation,” in J. Groenendijk *et al.* (eds.), *Truth, Interpretation, and Information* (Dordrecht: Foris, 1984), pp. 1-41. See also C. Swoyer, “The Metaphysics of Measurement,” in J. Forge (ed.), *Measurement, Realism, and Objectivity* (Dordrecht: D. Reidel, 1987), pp. 235-290.

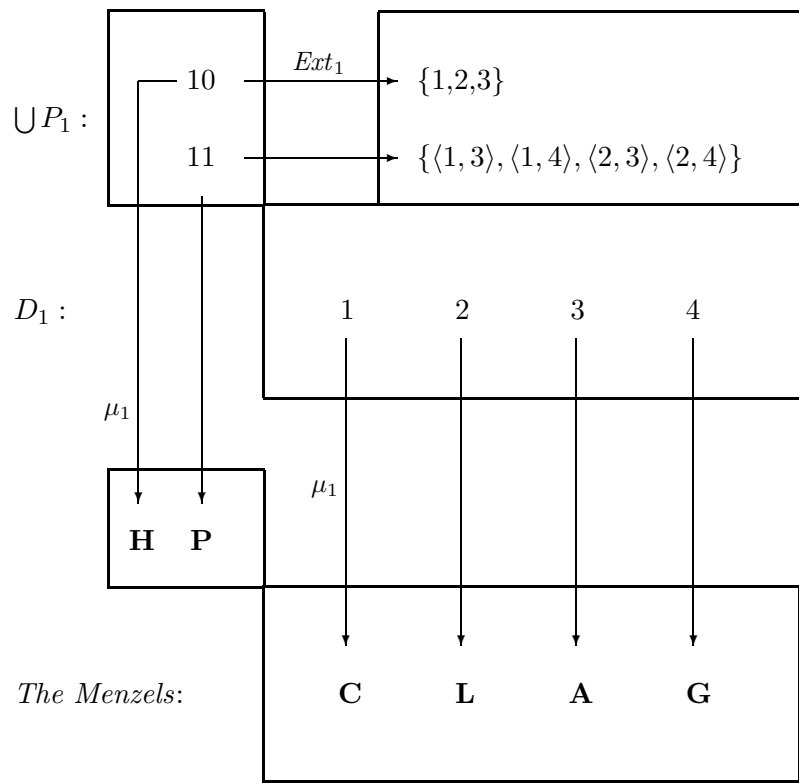

Figure 1: M_1

$\langle D, P, Ext \rangle$, say that an embedding μ for \mathbf{M} is \mathcal{L} -compatible just in case $rng(\mu|D)$ (i.e., the range of μ restricted to D) is the set of things over which the quantifiers of \mathcal{L} range in ordinary discourse, and $rng(\mu| \cup P)$ is a superset of the set of properties and relations expressed by the predicates of \mathcal{L} . (Of course, there might not be such an embedding.) \mathbf{M} is an *intended* model* for \mathcal{L} just in case it has a faithful \mathcal{L} -compatible embedding.

The intended model for \mathcal{L} , then, in our original sense, is just the intended* model that has the identity function as a faithful \mathcal{L} -compatible embedding. Thus, let \mathcal{L}_1 be an interpreted language designed to express the facts captured in our model \mathbf{M}_1 . So \mathcal{L}_1 consists of the unary predicate ‘is happy’, the binary predicate ‘is a parent of’, and the names ‘Chris’, ‘Liisa’, ‘Annie’, and ‘Galen’. \mathbf{M}_1 of course is an intended* model for \mathcal{L}_1 , but not the intended model; that distinction, obviously enough, belongs to the model \mathbf{M}_2 of Figure 2.

But there’s nothing privileged about \mathbf{M}_2 . For a given intended* model $\mathbf{M} = \langle D, P, Ext \rangle$ of \mathcal{L}_1 and any faithful \mathcal{L}_1 -compatible embedding μ for \mathbf{M} , let the *intended* interpretation* I of \mathcal{L}_1 be the pair $\langle \mathbf{M}, V \rangle$ such that $V \circ \mu$ (i.e., V composed with μ) maps each term and predicate of \mathcal{L}_1 to its actual semantic value. A formula of \mathcal{L}_1 is true, then, just in case it is true in an intended* model under the appropriate intended* interpretation. Similarly, of course, for languages and models in general.

Now all this is obvious enough, and, for plain vanilla semantics, even pointless—where we can avail ourselves of intended models to define truth, there is no need to muddy limpid waters with the added complexity of embeddings, intended* models, and intended* interpretations. Things, I think, are utterly different when we turn to modal semantics. Suppose I now want to represent not simple facts about my family, but simple *possibilities*; suppose, that is, I want to depict not how things are, but how they could have been. My family situation, for example, could have been much as depicted above, except that in addition I could have had a third child. Once again, I could draw a picture like the one above, this time with five figures rather than only four, the fifth labeled with, say, an X. Now in what way does this represent the possibility at hand? Not, I want to insist, in virtue of the fifth figure representing some merely possible family member the way the other four represent actual members. Rather, it is in virtue of a modal fact about the entire drawing: the drawing *could have been* such as to represent how things stand with my family, i.e., it could have been the case that each figure in the drawing represented some family member, and that each family member was represented by some figure in the drawing, and was represented

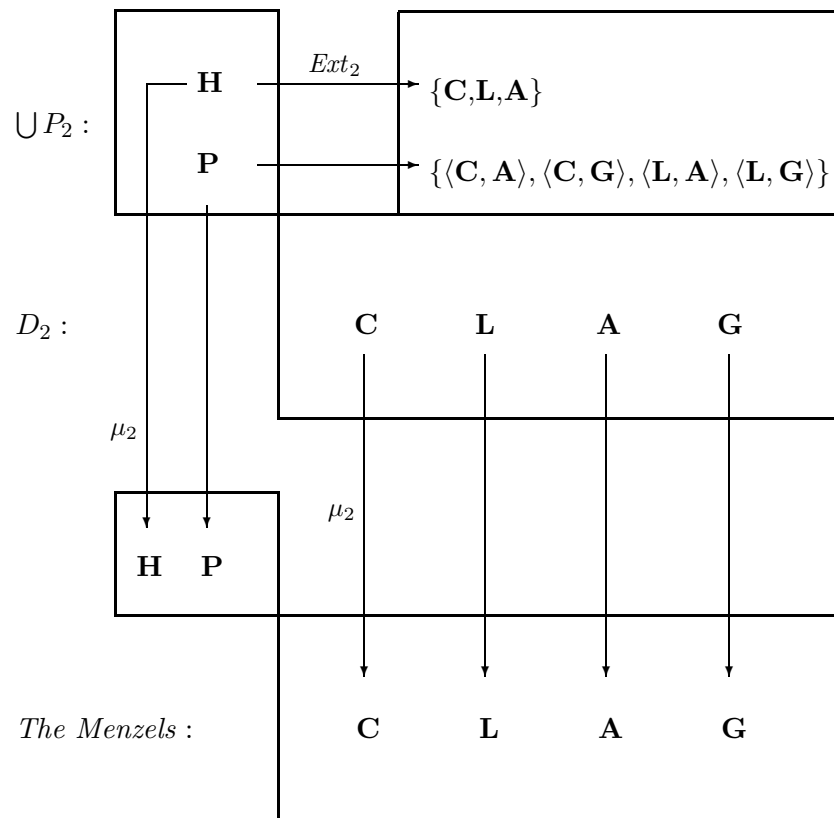

Figure 2: M_2

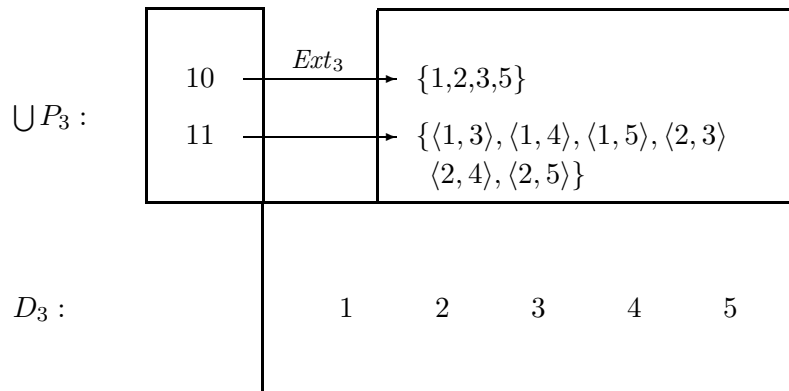

Figure 3: \mathbf{M}_3

correctly as being in a certain state (viz., happy or not). There is, I claim, no deeper modal fact of the matter than this.

Things are no different when we move to more abstract pictures, i.e., formal models. Consider the model \mathbf{M}_3 as depicted in Figure 3. As with the drawing, \mathbf{M}_3 represents the possibility at hand not in virtue of there actually being an embedding from D_3 onto possible and actual family members, or essences thereof, but rather because there *could* have been a faithful embedding for \mathbf{M}_3 that mapped elements of D_3 onto the members of my family that would have existed had the possibility in question been actual.

This simple conception of the representational powers of models is, to my mind, the key to understanding how possible world semantics pictures the modal facts. An initial image might be useful for setting the course of our argument. Suspend your skepticism for the moment and take the possibilist's vision of modal reality at face value; imagine, that is to say, that there really is a standard model \mathbf{M}^\diamond replete with possible worlds and their (in general) merely possible inhabitants. At the same time, however, like Plantinga and McMichael, allow that modality is primitive, not analyzable in terms of primitive worlds. Every modal statement thus yields at most an *equivalent* statement about worlds and their denizens, but no such statement is to be considered an *analysis* of the modal statement. Consider a model

$\mathbf{M}_4 = \langle W_4, @_4, D_4, P_4, Dom_4, Ext_4 \rangle$ isomorphic to \mathbf{M}^\diamond , but constructed only out of unproblematic (relatively speaking!) necessary beings; pure sets, say. In virtue of the isomorphism, of course, \mathbf{M}_4 would do just as well as \mathbf{M}^\diamond for defining truth for modal languages; structurally, \mathbf{M}_4 represents modal reality no less than \mathbf{M}^\diamond . Now, while retaining your belief in the primitiveness of modality, reinvoke your skepticism about worlds. The standard model drops away, but \mathbf{M}_4 endures with only pure sets in place of worlds and possibilia, as accurate a representation of modality as before.

The problem with this image, of course, is how to specify a possible worlds model like the \mathbf{M}_4 of our story in a way that makes clear how the model represents modality without appealing to the standard model and its untoward constituents. This is where the ideas above come into play. First a preliminary note. We might well rest content with possible worlds models that represent the modal facts pertaining only to certain subclasses of all the individuals there are—family members, stars, or items in the fridge—and with respect to only certain of the properties and relations that hold among them. The idea in the standard model, though, as well as in Plantinga’s haecceitist model, is that each index gives us a full-blown *world*, and that the domain at each index is the set of *all* individuals (or haecceities) existing in (exemplified in) that world.³¹ To accommodate an analogous idea, we will use the notion of a *completely faithful* embedding for an apv-model, where μ is completely faithful for $\mathbf{M} = \langle D, P, Ext \rangle$ just in case it is faithful, $rng(\mu| \cup P)$ is the set of all n -place relations, and $rng(\mu|D)$ is the set of all individuals.³² And say that \mathbf{M} itself is completely faithful if there is a completely faithful embedding for it. That noted, henceforth (unless otherwise stated) by ‘faithful’ I will mean ‘completely faithful’.

So what conditions would a modally accurate possible worlds model $\mathbf{A} = \langle W, @, D, P, Dom, Ext \rangle$ have to meet? To begin with, the “base” apv-model $\mathbf{A}(@) = \langle Dom(@), P, Ext_@ \rangle$ of \mathbf{A} must obviously be faithful. Next, we want a “comprehensiveness” condition, a condition that mirrors the idea that W^\diamond in the standard model is the set of *all* possible worlds—something like the following: no matter how things could have turned out, there must always be some index $w \in W$ such that the apv-model $\mathbf{A}(w)$ would have been an

³¹For the more cautious approach to worlds, see R. Stalnaker, *Inquiry* (Cambridge: MIT/Bradford Books, 1984).

³²It should be borne in mind, though, for those who might be dubious about the idea of a set of all individuals or n -place relations, that nothing which follows hangs on the legitimacy of these notions, since with minor complications we could make all the same moves with appropriately restricted domains.

accurate representation of the world; that is to say (and that is *only* to say), necessarily, there is an index $w \in W$ such that $\mathbf{A}(w)$ is faithful.

But this won't quite do as it stands, since \mathbf{A} could meet the condition even if $Dom(w) \cap Dom(w') = \emptyset$ for all $w, w' \in W$. In such a case, any element of D that would have represented Pete Rose, say, if things had been otherwise, would be distinct from any element of $Dom(@)$ that represents him in fact. This doesn't picture the facts in the right sort of way—such a model represents individuals as “modally fragile”, i.e., as such that, if things had been at all different, then no actually existing individual would have existed. To the contrary, we want to require that the very same entity (individual, property, or relation) would have been represented by the same element of our model no matter what, and that the same element of our model would necessarily have represented the same entity, had it existed. In the standard model this is accomplished by positing that the same individual can exist in more than one possible world; in the haecceitist model it is by postulating that the same haecceity can be exemplified in distinct propositional worlds. We can achieve the same “transworld” effect and at the same time avoid these arcana by appealing instead to embeddings. More precisely, we require (at least) that:

- \mathbf{C}_1 $\mathbf{A}(@)$ has a faithful embedding μ such that, necessarily, there is a $w \in W$ such that (i) $\mathbf{A}(w)$ has a faithful embedding μ' such that for all $b \in rng(\mu) \cap rng(\mu')$, $\mu^{-1}(b) = \mu'^{-1}(b)$, and (ii) for all $e \in \bigcup P \cup (Dom(@) \cap Dom(w))$, $\mu(e) = \mu'(e)$.

Now, \mathbf{C}_1 is essential to my account, and so we need to convince ourselves that \mathbf{A} 's satisfying it involves us in no unacceptable metaphysical commitments. We've supposed \mathbf{A} to be constructed out of pure sets or the like, so the elements of W and the apv-models $\mathbf{A}(w)$ all presumably exist necessarily. What might give one pause is this. I take embeddings just to be extensional functions—sets of ordered pairs. Thus, no embedding μ for $\mathbf{A}(@)$ of the sort required by \mathbf{C}_1 is going to be a necessary being, since its range—the set of second elements in the pairs that make it up—contains lots of contingent beings; you and me, for instance. Yet \mathbf{C}_1 seems to fly in the face of this; for the occurrence of the terms ' $rng(\mu)$ ' and ' μ^{-1} ' within the scope of the necessity operator seems to imply that $rng(\mu)$ and μ^{-1} (hence μ itself) must exist necessarily in order for \mathbf{C}_1 to hold.

Note, though, that neither $rng(\mu)$ nor μ^{-1} simpliciter is referred to in \mathbf{C}_1 . Rather, the terms ' $rng(\mu)$ ' and ' μ^{-1} ' in both cases are parts of more

complex terms used to describe, in the former case, a subset of $rng(\mu)$ that would have existed had things been otherwise, and in the latter, elements in our model \mathbf{A} that would have been mapped to those objects. The use of these more complex terms thus no more entails that $rng(\mu)$ and μ^{-1} themselves would have existed even if members of $rng(\mu)$ hadn't than does the occurrence of 'John' in the statement 'If John's brother had been an only child, he would have been spoiled' entail that John would have existed if the antecedent had been true. To see this more clearly, we can simply rephrase \mathbf{C}_1 as a slightly less formal (though, as we'll see, not easily generalizable) condition:

$\mathbf{A}(@)$ has a faithful embedding μ such that, no matter how things might have gone (i.e., necessarily), some apv-model $\mathbf{A}(w)$ ($w \in W$) would have had a faithful embedding μ' such that (i) every actually existing object b that would have existed (i.e., every $b \in rng(\mu) \cap rng(\mu')$) would have had the same element of $Dom(@) \cap Dom(w)$ mapped to it by μ' as is mapped to it by μ in fact (i.e., $\mu^{-1}(b) = \mu'^{-1}(b)$), and (ii) every element of $\bigcup P \cup (Dom(@) \cap Dom(w))$ would have been mapped to the same object by μ' that μ maps it to in fact.

This rendering of the condition is, I think, wholly transparent and above reproach.

We cannot yet rest content, however, for things are more complicated than this. \mathbf{C}_1 ensures that every individual is necessarily tied to exactly one element of the domain D of our model \mathbf{A} (relative to a given embedding for $\mathbf{A}(@)$). But to get things right, we must ensure that the same is true (to speak with the vulgar) for all possible objects—that is to say (and that is *only* to say), we must ensure that the same *would have been* the case had things been otherwise, and in particular, had there been things other than those that exist in fact.

An example will make the matter clearer. I could have had a third child who was not a philosopher, $\diamond \exists x(Txm \wedge \neg Px)$. By \mathbf{C}_1 , $\mathbf{A}(@)$ has a faithful embedding μ such that if I had had a third child c who was not a philosopher, one of our apv-models $\mathbf{A}(w')$ would have had a faithful embedding μ' such that $\mu'^{-1}(\text{me}) = \mu^{-1}(\text{me})$, $\mu'^{-1}(\text{being a philosopher}) = \mu^{-1}(\text{being a philosopher})$, and such that $\mu'^{-1}(c) \notin Ext(\mu'^{-1}(\text{being a philosopher}))$. That is, μ' would have mapped the same element e of D to me that μ does in fact; μ' would have mapped the same element p of $\bigcup P$ to the property of

being a philosopher that μ does in fact; and, since my third child would not on the scenario we've envisioned have been a philosopher, the element of D that would have been mapped to her by μ' would not have been a member of the extension of p in $\mathbf{A}(w')$.

Now, it is also true that if I'd had a third child who wasn't a philosopher, she might have been one nonetheless, $\diamond\exists x(Txm \wedge \neg Px \wedge \diamond Px)$. However, the closest we get to representing this fact given \mathbf{C}_1 is the existence of another model $\mathbf{A}(w'')$ that could have had an embedding μ'' similar to the one described for $\mathbf{A}(w')$ above except that the element of D that μ'' would have been mapped to my third child would have been in the extension of p in $\mathbf{A}(w'')$ after all. But all this guarantees is the truth of the conjunctive proposition that I could have had a third child who wasn't a philosopher and I could have had one who was, $\diamond\exists x(Txm \wedge \neg Px) \wedge \diamond\exists x(Txm \wedge Px)$. For \mathbf{A} to represent the above fact correctly—the fact that I could have had a non-philosophical third child such that *she* might have been a philosopher—we should have to insist in addition that the embedding μ'' for $\mathbf{A}(w'')$ would still have mapped $\mu^{-1}(\text{me})$ ($= \mu'^{-1}(\text{me})$) to me, $\mu^{-1}(\mathbf{being\ a\ philosopher})$ ($= \mu'^{-1}(\mathbf{being\ a\ philosopher})$) to the property of being a philosopher, and *the very same element* $\mu'^{-1}(c)$ of D to c . That is, just as we require that I could have been represented by the same element of D no matter what, we also must require that, if things had been different, any object that *would have* existed could necessarily have been represented by the same element of D as well.

When we look at the logical form of the above possibility we see that what most saliently distinguishes it from the sort of case that motivates \mathbf{C}_1 is, first, its modal *degree*³³—it involves a second modal operator nested within the scope of another—and the fact that a variable that is quantified within the scope of the wider operator is quantified *into* the scope of the narrower. What this form depicts is the possibility of an object which is itself the subject *de re* of a further possibility. But it might well be, as in our example, that there is no such object in fact. There is thus no guarantee that

³³Where $degree(\varphi) = 0$ for atomic formulas, $degree(\neg\varphi) = degree(\forall x\varphi) = degree(\exists x\varphi) = degree(\varphi)$, $degree(\varphi * \psi) = \max(degree(\varphi), degree(\psi))$ ($*$ any binary connective), and $degree(\Box\varphi) = degree(\Diamond\varphi) = degree(\varphi) + 1$. See, e.g., G. E. Hughes and M. J. Creswell, *An Introduction to Modal Logic* (London: Methuen and Co., Ltd., 1968), p. 50. Not all nesting, of course, gives rise to similar difficulties; e.g., where one's underlying logic is S5, nesting involving mere *iteration* of modal operators is in effect eliminable and the added conditions below unnecessary. It is quantification into the scope of nested modal operators that gives rise to the sorts of cases we are concerned with here.

our model \mathbf{A} , in satisfying only \mathbf{C}_1 , contains an apv-model that represents the relation between the two possibilities that make up the larger possibility correctly.

To make the above precise, then, for our model \mathbf{A} to capture possibilities that involve nested modalities, the following more general version of \mathbf{C}_1 must hold:

\mathbf{C}_2 $\mathbf{A}(@)$ has a faithful embedding μ such that, necessarily, there is a $w_1 \in W$ such that $\mathbf{A}(w_1)$ has a faithful embedding μ_1 such that, (i) for all $b \in \text{rng}(\mu) \cap \text{rng}(\mu_1)$, $\mu^{-1}(b) = \mu_1^{-1}(b)$, and (ii) for all $e \in \bigcup P \cup (\text{Dom}(@) \cap \text{Dom}(w_1))$, $\mu(e) = \mu_1(e)$, and such that, necessarily, there is a $w_2 \in W$ such that $\mathbf{A}(w_2)$ has a faithful embedding μ_2 such that (i') for all $b \in \text{rng}(\mu) \cap \text{rng}(\mu_2)$, $\mu^{-1}(b) = \mu_2^{-1}(b)$, and for all $b \in \text{rng}(\mu_1) \cap \text{rng}(\mu_2)$, $\mu_1^{-1}(b) = \mu_2^{-1}(b)$, and (ii') for all $e \in \bigcup P \cup (\text{Dom}(@) \cap \text{Dom}(w_2))$, $\mu(e) = \mu_2(e)$, and for all $e \in \bigcup P \cup (\text{Dom}(w_1) \cap \text{Dom}(w_2))$, $\mu_1(e) = \mu_2(e)$.

\mathbf{C}_2 doesn't afford as straightforward a subjunctive paraphrase as \mathbf{C}_1 . The reason for this is that there is no operator in natural language whose semantic effect on sentences within a nested modality is analogous to, but more delicate than, the effect of 'actually' or 'in fact'; no operator that, so to speak, bumps us up only one level of modal nesting rather than all the way out.³⁴ The best we can do is something like the following, somewhat stilted reconstrual. The indentations correspond to the two levels of nesting:

$\mathbf{A}(@)$ has a faithful embedding μ such that, no matter how things might have gone (i.e., necessarily),

- 1) some apv-model $\mathbf{A}(w_1)$ would have had a faithful embedding μ_1 such that, such that (i) every actually existing object b that would have existed would have had the same element of $\text{Dom}(@) \cap \text{Dom}(w_1)$ mapped to it by μ_1 as is mapped to it by μ in fact, and (ii) every element of $\bigcup P \cup (\text{Dom}(@) \cap \text{Dom}(w_1))$ would have been mapped to the same object by μ_1 that μ maps it to in fact; and (iii) no matter how *else* things might have gone,

³⁴Hodes' operator \downarrow gives precise formal expression to this idea. See his "Modal Logics which Enrich First-order S5," *Journal of Philosophical Logic* 13 (1984), pp. 423-454, esp. pp. 425-6.

- 2) there still would have been a faithful embedding μ_2 for some apv-model $\mathbf{A}(w_2)$ such that (i) every actually existing object b that would have existed in this case (i.e., every $b \in \text{rng}(\mu) \cap \text{rng}(\mu_2)$) would have had the same element of $\text{Dom}(@) \cap \text{Dom}(w_2)$ mapped to it by μ_2 as is mapped to it by μ in fact, and every object b that would also have existed in the above case (i.e., every $m \in \text{rng}(\mu_1) \cap \text{rng}(\mu_2)$) would have had the same element of $\text{Dom}(w_1) \cap \text{Dom}(w_2)$ mapped to it by μ_2 as would have been mapped to it in the above case by μ_1 and (ii) every element of $\bigcup P \cup (\text{Dom}(@) \cap \text{Dom}(w_2))$ would have been mapped to the same object by μ_2 that μ maps it to in fact, and every element of $\bigcup P \cup (\text{Dom}(w_1) \cap \text{Dom}(w_2))$ would have been mapped to the same object by μ_2 that μ_1 would have mapped to it in the above case.

There is, of course, no finite bound on the modal degree of such possibilities. There are, for instance, straightforward extensions of the above example of higher degree—I could have had a third child who was not a philosopher but might have been both a philosopher and the mother of a child who was not a violinist but might have been, $\diamond \exists x (Txm \wedge \neg Px \wedge \diamond (Px \wedge \exists y (Mxy \wedge \neg Vy \wedge \diamond Vy)))$. Here, a variable that is quantified within the scopes of *two* modal operators, is quantified into the scope of yet a third. Similar extensions can be given for any finite degree. This calls for the following generalization of \mathbf{C}_1 and \mathbf{C}_2 , where $@$ is w_0 :

\mathbf{C}_n $\mathbf{A}(w_0)$ has a faithful embedding μ_0 such that, necessarily, there is a $w_1 \in W$ such that $\mathbf{A}(w_1)$ has a faithful embedding μ_1 such that, for all $b \in \text{rng}(\mu_0) \cap \text{rng}(\mu_1)$, $\mu_0^{-1}(b) = \mu_1^{-1}(b)$, and for all $e \in \bigcup P \cup (\text{Dom}(@) \cap \text{Dom}(w_1))$, $\mu_0(e) = \mu_1(e)$, and such that, necessarily, \dots , there is a $w_n \in W$ such that $\mathbf{A}(w_n)$ has a faithful embedding μ_n such that for all $i < n$, for all $b \in \text{rng}(\mu_i) \cap \text{rng}(\mu_n)$, $\mu_i^{-1}(b) = \mu_n^{-1}(b)$, and for all $e \in \bigcup P \cup (\text{Dom}(w_i) \cap \text{Dom}(w_n))$, $\mu_i(e) = \mu'_n(e)$.

For our model \mathbf{A} to represent modality accurately, then, we require that there be a specific faithful embedding μ^* for $\mathbf{A}(@)$ such that \mathbf{C}_n holds for all natural numbers n when μ^* is plugged in for μ_0 . We can then be sure that \mathbf{A} pictures the modal facts correctly regardless of how deeply nested the modalities within those facts might be.

One last condition. \mathbf{C}_n ensures that there will necessarily be apv-models with faithful embeddings that (loosely speaking!) would have agreed with other possible embeddings where their domains and ranges would have overlapped. For \mathbf{A} to be a fully adequate representation of modality, though, we need to be sure that *each* of its apv-models could be faithfully embedded in a similarly congenial way relative to other possible embeddings, and this (so far as I can see) is *not* guaranteed by \mathbf{C}_n . \mathbf{A} might satisfy \mathbf{C}_n for all n relative to μ^* , even though it may well contain apv-models that couldn't be faithfully embedded at all, or that, e.g., could be faithfully embedded only by mapping $\mu^{*-1}(\text{Pete Rose})$, say, to a garden vegetable, or $\mu^{*-1}(\mathbf{wisdom})$ to the property **being a prime number**. Such models would be in a sense *modally incoherent* relative to μ^* . This suggests the prospect of \mathbf{A} itself being modally incoherent in the sense that, for any embedding μ for $\mathbf{A}(@)$ that validates \mathbf{C}_n for all n , there is nonetheless an apv-model $\mathbf{A}(w)$ that is modally incoherent relative to μ . This specter needs to be banished.

How so? At the least complex level, what we're requiring here is that, relative to μ^* (or some similar embedding),

CO For all $w \in W$, it is possible that there is a faithful embedding μ for $\mathbf{A}(w)$ such that for all $b \in \text{rng}(\mu^*) \cap \text{rng}(\mu)$, $\mu^{*-1}(b) = \mu^{-1}(b)$, and for all $e \in \bigcup P \cup (\text{Dom}(@) \cap \text{Dom}(w))$, $\mu^*(e) = \mu(e)$.

As we found with \mathbf{C}_1 , though, we need to say more, since possibilities involving nested modalities give rise to more complex examples of potential modal incoherence. Once again, for example, I could have had a third child c . By \mathbf{C}_1 , assuming \mathbf{A} satisfies \mathbf{C}_n (for all n) relative to μ^* , there would have been an apv-model $\mathbf{A}(w)$ that had a faithful embedding μ' that would have mapped some element e of D to c . But suppose, had that been the case, there would have been another model $\mathbf{A}(w')$ that could only have been faithful by mapping e to things other than c ; suppose, that is, that $\mathbf{A}(w')$ would have been incoherent relative to μ' . And suppose there would have been a similarly incoherent model for any faithful embedding for $\mathbf{A}(w)$; and suppose also that a similar situation would have arisen for any faithful embedding for $\mathbf{A}(@)$ other than μ^* . Then \mathbf{A} would still have to be counted modally incoherent, even if it had satisfied **CO**.

To deal with this case we should have to generalize **CO** to a principle—**CO₂** say—that rules out incoherence arising from possibilities involving a nested modality, i.e., possibilities of degree two. But of course similar examples could be generated by yet more deeply nested operators; there is,

more generally, no finite bound on the depth at which one might find this sort of incoherence. Hence, as with \mathbf{C}_1 , \mathbf{CO} has to be generalized for all n . Integrating this generalization with \mathbf{C}_n , we arrive at the following (admittedly hairy) overarching schema. (Note that (ii) below—the generalization of \mathbf{CO} —is within the scope of all prior modal operators):

\mathbf{C}_{nm} $\mathbf{A}(w_0)$ has a faithful embedding μ_0 such that, necessarily, (i) there is a $w_1 \in W$ such that $\mathbf{A}(w_1)$ has a faithful embedding μ_1 such that, for all $b \in \text{rng}(\mu_0) \cap \text{rng}(\mu_1)$, $\mu_0^{-1}(b) = \mu_1^{-1}(b)$, and for all $e \in \bigcup P \cup (\text{Dom}(\textcircled{a}) \cap \text{Dom}(w_1))$, $\mu(e) = \mu_1(e)$, and such that, necessarily, \dots , there is a $w_n \in W$ such that $\mathbf{A}(w_n)$ has a faithful embedding μ_n such that for all $i < n$, for all $b \in \text{rng}(\mu_i) \cap \text{rng}(\mu_n)$, $\mu_i^{-1}(b) = \mu_n^{-1}(b)$, and for all $e \in \bigcup P \cup (\text{Dom}(w_i) \cap \text{Dom}(w_n))$, $\mu_i(e) = \mu'_e$; and (ii) for all $v_1, \dots, v_m \in W$, possibly, there is a faithful embedding γ_1 for $\mathbf{A}(v_1)$ such that, for all $i < n$, for all $b \in \text{rng}(\mu_i) \cap \text{rng}(\gamma_1)$, $\mu_i^{-1}(b) = \gamma_1^{-1}(b)$, and for all $e \in \bigcup P \cup (\text{Dom}(w_i) \cap \text{Dom}(v_1))$, $\mu_i(e) = \gamma_1(e)$, and possibly, \dots , there is a faithful embedding γ_m for $\mathbf{A}(v_m)$ such that for all $i < n, j < m$ for all $b \in \text{rng}(\mu_i) \cap \text{rng}(\gamma_m)$, $\mu_i^{-1}(b) = \gamma_m^{-1}(b)$, for all $b \in \text{rng}(\gamma_j) \cap \text{rng}(\gamma_m)$, $\gamma_j^{-1}(b) = \gamma_m^{-1}(b)$, for all $e \in \bigcup P \cup (\text{Dom}(w_i) \cap \text{Dom}(v_m))$, $\mu_i(e) = \gamma_m(e)$, and for all $e \in \bigcup P \cup (\text{Dom}(v_j) \cap \text{Dom}(v_m))$, $\gamma_j(e) = \gamma_m(e)$.

By integrating \mathbf{C}_n with \mathbf{CO}_m , we ensure that if our model \mathbf{A} satisfies \mathbf{C}_{nm} , for any n and m , then, first, relative to some faithful embedding μ , \mathbf{A} will represent any possibility of degree n correctly, and second, *relative to that same embedding*, there will be no modal incoherence arising from possibilities of degree m . Accordingly, for any faithful embedding μ for $\mathbf{A}(\textcircled{a})$, say that \mathbf{A} is (*modally*) *adequate relative to μ* just in case \mathbf{C}_{nm} holds for all natural numbers n, m when μ is plugged in for μ_0 , and say that \mathbf{A} itself is (*modally*) *adequate* just in case it is adequate relative to some embedding.

Truth for interpreted modal languages is now straightforward. Let \mathcal{L} be such a language, and $\mathbf{A} = \langle W, \textcircled{a}, D, P, \text{Dom}, \text{Ext} \rangle$ a possible worlds model. As before, say that an embedding μ for $\mathbf{A}(\textcircled{a})$ is \mathcal{L} -*compatible* just in case $\text{rng}(\mu | \text{Dom}(\textcircled{a}))$ is the set of things over which the quantifiers of \mathcal{L} range in ordinary discourse, and $\text{rng}(\mu | \bigcup P)$ is a superset of the set of properties and relations expressed by the predicates of \mathcal{L} . (Since we have been considering only *completely* faithful models, we will assume that the quantifiers of \mathcal{L} are

unrestricted, and hence that $\text{rng}(\mu|_{\text{Dom}(@)})$ is the set of all individuals). \mathbf{A} is an *intended* model* for \mathcal{L} just in case there is an \mathcal{L} -compatible embedding μ for $\mathbf{A}(@)$ such that \mathbf{A} is adequate relative to μ . The *intended* interpretation* I for \mathcal{L} relative to \mathbf{A} and μ , then, is the pair $\langle \mathbf{A}, V \rangle$ such that $V \circ \mu$ takes each term and predicate to its actual semantic value. As in the nonmodal case, then, a formula of \mathcal{L} is *true* just in case it is true in an intended* model under the appropriate intended* interpretation. I assume henceforth that there are intended* models for any reasonable modal language.

6 Adequate Models and Truth Conditions

Let's take stock. We've laid out the conditions for a possible worlds model $\mathbf{A} = \langle W, @, D, P, \text{Dom}, \text{Ext} \rangle$ to be modally adequate, to represent the modal facts accurately. Its constituents are familiar abstract objects of some ilk—we've supposed pure sets; its "worlds" W a mere set of indices;³⁵ its "actual world" $@$ an arbitrary member of W ; its "possible individuals" D an arbitrary set. Unlike the intended models discussed above, the representational capacity of an adequate model, and its corresponding appropriateness for defining truth, lie not in any intrinsic properties of its constituents, but only in a certain rather complex modal property of the model as a whole. A formal theory of modal truth demands nothing more.

But there is perhaps more to a theory of truth than truth simpliciter. For Plantinga and McMichael, one of the chief goals of modal semantics is to provide *truth conditions* for modal statements, not just an extensionally correct theory of truth. A proper semantics will describe for each sentence φ in its turn what the world must be like in order for φ to be true in terms of the constituents of the semantics' intended model.³⁶ By contrast, the constituents of an arbitrary adequate model \mathbf{A} that figure into the truth value of a given sentence φ in \mathbf{A} in and of themselves have no bearing whatsoever on its truth or falsity simpliciter;³⁷ rather, its truth value, as noted, is a function of the model as a whole. Thus, adequate models, while providing extensionally correct truth value distributions for modal statements,

³⁵See the quote from Barwise and Perry in the introduction.

³⁶Thus McMichael: "I have not constructed the semantics simply to segregate the valid and invalid formulas of a first-order language. I have tried in addition to give a semantics which, for any given first-order modal statement, reveals the *form* of its truth conditions." NAMS, p. 96. See also PAPW, p. 63, and APW, Section 5: "Essences and Truth Conditions."

³⁷Except perhaps by accident, Gettier-style.

are unable to provide genuine, model-independent truth conditions.³⁸

Strictly speaking, this objection is correct. Since there are no intended models on our approach, only intended* models, the truth conditions for the sentences of a language generally cannot be identified with the truth conditions for the sentences in some distinguished model. But that just means we have to look a little more carefully. Consider the statement (1) again, i.e.,

- (1) There could have been objects distinct from every actually existing object.

or perhaps more precisely,

- (2) Possibly, there exists something distinct from every actually existing thing.

(2) is true, on our theory, just in case it is true in some intended* (hence adequate) model (for an interpreted language containing a counterpart of (2)) under the appropriate intended* interpretation. So let $\mathbf{A} = \langle W, @, D, P, Dom, Ext \rangle$ be such a model, and let μ^* be an embedding relative to which \mathbf{A} is adequate. Then (2) is true in \mathbf{A} (when all is said and done) iff there is a $w \in W$ such that for some $e \in Dom(w)$, $e \notin Dom(@)$. By **CO** (i.e., $\mathbf{C}_{0,1}$), this is true only if there could have been a faithful embedding μ for $\mathbf{A}(w)$ that would have “agreed” with μ^* as far as it would have gone; in particular, μ could not have mapped e onto any actually existing thing. But since embeddings are total functions, μ would have had to have mapped e onto *something*, hence it would have mapped it onto something that doesn’t exist in fact. Hence, (2) is true only if there could have existed something distinct from every actually existing thing. By similar reasoning, we can show that it follows from **C₁** (i.e., $\mathbf{C}_{1,0}$) that if there could have existed something distinct from every actually existing thing, then there is a $w \in W$ such that for some $e \in Dom(w)$, $e \notin Dom(@)$, i.e., then (2) is true in \mathbf{A} , hence true. Thus, (1) and (2) are true iff it is possible that there exists something distinct from every actually existing thing.

Consider a second example:

- (3) Necessarily, if Quine exists, then he is human.

³⁸Compare McMichael’s criticism of nonrealist semantics in PAPW, pp. 63-4.

Again, (3) is true just in case it is true in some intended* model under the right intended* interpretation. So let $\mathbf{A} = \langle W, @, D, P, Dom, Ext \rangle$ be such a model, let μ^* be an embedding relative to which \mathbf{A} is adequate, and let $\langle \mathbf{A}, V \rangle$ be the appropriate interpretation, viz., the one such that, where $V \circ \mu(\text{'Quine'}) = \text{Quine}$, $V \circ \mu(\text{'exists'}) = \mathbf{existence}$, and $V \circ \mu(\text{'human'}) = \mathbf{humanity}$. (3) is true in \mathbf{A} iff for all $w \in W$, either $V(\text{'Quine'}) \notin Ext(V(\text{'exists'}), w)$ or $V(\text{'Quine'}) \in Ext(V(\text{'human'}), w)$. But if that's true, then it follows that, necessarily, either Quine doesn't exist or he is human. For suppose not. Then Quine could have existed without being human. Had this occurred, then by \mathbf{C}_1 , there would have been a faithful embedding μ' for some $w \in W$ that would have agreed with μ^* as far as it would have gone. In particular, it would have agreed with μ^* on the values of $V(\text{'exists'}) (= \mu^{*-1}(\mathbf{existence}))$, $V(\text{'human'}) (= \mu^{*-1}(\mathbf{humanity}))$, and, since Quine would have existed (albeit as a nonhuman), $V(\text{'Quine'}) (= \mu^{*-1}(\text{Quine}))$. Since μ' would have been faithful, it follows that $V(\text{'Quine'}) \in Ext(V(\text{'exists'}), w)$ and $V(\text{'Quine'}) \notin Ext(V(\text{'human'}), w)$. But by assumption, for all $w \in W$, either $V(\text{'Quine'}) \notin Ext(V(\text{'exists'}), w)$ or $V(\text{'Quine'}) \in Ext(V(\text{'human'}), w)$, contradiction. Thus, (3) is true in \mathbf{A} only if, necessarily, either Quine doesn't exist or he is human. By similar reasoning, using both \mathbf{C}_1 and \mathbf{CO} , we can show the converse. Thus, (3) is true iff, necessarily, either Quine doesn't exist or he's human, i.e., iff, necessarily, if Quine exists, then he is human.

The point is that, when we move beyond model-relative truth conditions and think about the further conditions we've imposed on adequate models, we do in fact get straightforward, nonrelative truth conditions, viz., to be explicit,

- (4) 'Possibly, there exists something distinct from every actually existing thing' is true iff, possibly, there exists something distinct from every actually existing thing.

and

- (5) 'Necessarily, if Quine exists, then he is human' is true iff, necessarily, if Quine exists, then he is human.

Now, of course, these truth conditions are not extensional. But how could things be otherwise? Modality—the very paragon of intensionality—has been an irreducible and essential primitive in my story all along. Thus, I count the modal operators in the same semantical company with quantifiers

and connectives: we offer no deeper analysis of ‘every’ or ‘not’ than the ordinary meanings of the words; to take modality as primitive is simply to accord the same status to ‘possibly’ and ‘necessarily’.³⁹

Nonetheless, there is likely to be unease, a sense that something has been lost. Both Plantinga and McMichael suggest that their semantic theories yield truth conditions that are somehow more “illuminating” than the rather mundane truth conditions above; that the resulting truth conditions provide “literal explanation and articulation of our modal notions” that is otherwise lacking.⁴⁰ But it is hard to see the advantage. Consider Plantinga’s analysis of (1) once again, in its guise as (2):

- (6) ‘Possibly, there exists something distinct from every actually existing thing’ is true iff there is a world w and an essence e such that e is exemplified in w and e is not exemplified in fact.

Modal operator gives way dutifully to extensional quantifier. But is there any gain, any increased illumination of the modal facts? The lack of any overt modalities in the truth conditions on the right-hand side might foster an illusion of explanation, of an *analysis* of the modal operator in terms of a quantifier over worlds. But in order genuinely to *understand* the truth conditions for (2), we need to understand what worlds and haecceities are; when all is said and done, the truth conditions look like this:

- (7) ‘Possibly, there exists something distinct from every actually existing thing’ is true iff there is a proposition w such that (i) it is possible that w be true, and (ii) for all propositions p , either, necessarily, if w is true, then so is p , or, necessarily, if w is true, then so is *not*- p , and (iii) there is a property e such that (a) it is possible for something to have e , (b) necessarily, whatever has e has it essentially, and (c) necessarily, if x has e , then it is not possible for anything but x to have it, and

³⁹This is the typical medieval approach to modal truth conditions. See, e.g., A. Freddoso and H. Schuurman, *Ockham’s Theory of Propositions: Part II of the Summa Logicae* (University of Notre Dame Press, 1980), esp. Section 5 of the Introduction by Freddoso. J. E. Nolt also makes a similar move in “What are Possible Worlds?” *Mind* 95 (1986), pp. 432-445. On modal truth theories generally, see Gupta, *op. cit.*, also M. Davies, “Weak Necessity and Truth Theories,” and C. Peacocke, “Necessity and Truth Theories” in the same volume, pp. 415-439 and pp. 473-500 resp.

⁴⁰See PAPW, p. 53, NN, p. 126.

(iv) necessarily, if w is true, then something has e , and (v) nothing has e in fact.

When the smoke clears, the haecceitist truth conditions for (2) are no less overtly intensional than on our alternative account. Nor is there any difference in the *structure* of the truth conditions that might constitute some sort of conceptual gain, e.g., no nested modal operators; rather, to grasp the truth conditions we need at a minimum whatever pretheoretic modal facility it takes to grasp (2) itself. The same applies no less to the role semantical truth conditions for (2).⁴¹ First impressions to the contrary, then, there is no deeper illumination, explanation, or articulation of our modal notions to be gained from either haecceitist or role semantics. Indeed, there is perhaps positive loss, since we must introduce new and unfamiliar objects into our ontology just to get those semantic theories off the ground (assuming, of course, we have no *other* use for them).

Nonetheless, it might be felt that something is still missing, that truth conditions of the sort we've given don't really *account* for the truth value of modal statements like (2); that modal truth so understood is not sufficiently rooted in reality. Rather, there must be *objects* to serve as the "ground" of modal truth, entities *in virtue of whose* properties and relations our modal statements are true or false. McMichael seems to have something like this in mind when he claims that, in a "good" semantical account of truth, "there are *real entities* [as opposed to mere formal constructs] which exhibit the given semantic structure," i.e., the structure abstractly characterised in the formal semantics proper.⁴² And a similar thought seems to lie behind Plantinga's insistence that the actualist "*must* appeal to essences" in order to give acceptable truth conditions for (2).⁴³ We are then able to say that it is *because* some possible world (appropriately conceived) and some role or haecceity are related the way they are that (2) is true.

There is something to this. It seems quite reasonable that what is possible, or necessary for that matter, must in *some* sense be grounded in what exists, be it haecceities and their properties, combinatorial relations that could obtain between the most basic elements of the physical universe, or

⁴¹It's actually not clear exactly what those truth conditions are; see NAMS, p. 99, fn. 12; also pp. 77-79. But no matter what they turn out to be, they will be formulated in terms of roles. And the definition of a role (p. 88) is stated in terms of one property's *including* another—i.e., being such that, necessarily, if anything has the first, then it has the second—and so also must appeal to a primitive understanding of the modal operators.

⁴²NAMS, p. 97, my emphasis.

⁴³APW, p. 268, my emphasis.

the power of God. But I haven't been so ambitious as to try to answer *that* question. My claim has only been that, if we are going to take modality in the broadly logical sense at face value, then there is no reason to ask for any more than a homophonic theory of modal truth conditions: for a modal statement to be true—just as in the nonmodal case—is for things to be as the statement says. Granted, this answer to the question of the form of modal truth conditions does not answer any questions about the metaphysical ground of modal truth, whatever that might be. But no surprise; it's a different question.

Blame must be laid at the feet of the extensionalist fallacy for the idea that anything more should seem necessary. *If* modal truth must be cashed in terms of an intended model \mathbf{M} , then the truth conditions for a sentence \mathbf{S} must be the truth conditions generated directly in \mathbf{M} . And since \mathbf{M} is an intended model, a model cut straight from the world itself, what more direct and revealing account could one hope to find of the ground of its truth value? But modal truth needn't be so cashed; intended models are otiose. Freed from their grip in modal semantics, nothing deeper (and nothing less deep) than a homophonic account of modal truth conditions—silent as it is on questions of the ground of modal truth—is to be expected.

7 Conclusion

I've tried to steer a course between two views of possible world semantics that are often taken to be exhaustive: on the one hand, that it has only heuristic value, and on the other, that it can yield a genuine theory of truth for our modal discourse, but only at great ontological cost. To the contrary, rightly construed, one can take the semantics to provide a rich theory of truth and model-independent truth conditions without any untoward metaphysical commitments.

This is of course just a beginning. I have, for instance, adopted a relatively naive picture of the nature of formal representation for the sake of brevity and ease of exposition. Little was said about the problems of “total” models like those above, or of the representation of less than total alternative possibilities.⁴⁴ Nothing at all was said about the issue of “granularity” in representational systems, or about problems of temporality and change,

⁴⁴See R. Stalnaker, “Possible Worlds and Situations,” *Journal of Philosophical Logic* 15 (1986), pp. 109-123, and J. Perry, “From Worlds to Situations,” pp. 83-107 of the same issue.

or the specific nature of representation in Montague grammar. What the above promises though, I believe, is a framework in which these issues can be fruitfully addressed in full compliance with actualist scruples.⁴⁵

Department of Philosophy
510 Blocker
Texas A&M University
College Station, Texas 77843-4237

⁴⁵This paper was initially conceived when I was a fellow at the Center for Philosophy of Religion at the University of Notre Dame during the spring of 1988. Most of it was written there and during the following summer in College Station under a grant from the Texas A&M College of Liberal Arts. My thanks go out to both institutions. I would like in particular to thank Fred Freddoso, Michael Kremer, Tom Morris, and Ed Zalta for extensive discussion of these issues over the years, and Bob Burch, Al Plantinga, and Chris Swoyer for incisive comments on early drafts that significantly improved the paper. Burch's comments in particular were extraordinarily detailed and penetrating. Special thanks to Al Plantinga, who first taught me about the metaphysics of modality, and whose work continues to be my starting point.